



INSTALLATION INSTRUCTIONS

JEEP JK SECURITY CONSOLE INSERT #139

Call (970) 564-1762 for Technical Support

Please read and fill out the enclosed warranty registration card to activate your warranty.

PARTS CHECKLIST

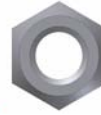

(2) 5/16-18 x 4 1/2" HEX CAP SCREW, GRADE 8

(2) 5/16-18 HEX NYLON INSERT NUTS



(4) 5/16" USS FLAT WASHERS

(10) #6 BLACK WASHERS

(14) #6-32 X 3/4" SCREW, BLACK

RUBBER SEAL

TOOLS NEEDED

- T-20 Torx bit or wrench (To remove OEM console)
- T-30 Torx bit or wrench (To remove OEM console)
- Flat Head Screwdriver (If OEM console has electric window switches in the rear)
- 5/64" Allen bit or wrench

Tools for optional additional mounting security

- Electric drill
- 3/8" Drill bit
- Marker or pencil
- Silicone sealant (Recommended)
- 1/2" Socket and ratchet
- 1/2" Wrench

ATTENTION:

FREQUENT LUBRICATION IS NECESSARY ON THE LOCKING SYSTEM

The pushbutton lock contains an "O" ring seal to protect the interior from dust and water. If this mechanism is not lubricated regularly it will become difficult to operate and it may not return to its home position preventing the key from operating the lock. If this happens simply pull up on the pushbutton to manually bring it back to its home position. Lubricate the pushbutton with a light lubricant such as silicone spray. The pushbutton may have to be periodically disassembled and cleaned.

PLEASE READ ALL INSTRUCTIONS THOROUGHLY BEFORE STARTING INSTALLATION.

1. On the OEM console detach the original insert (#27 - Fig 1) by removing the (4) original torx mounting screws (#15 – Fig 1, these will be reused) and (10) original torx side screws (#28 – Fig 1, these will not be reused).
2. Remove the (4) original torx screws (#28 – Fig 1, these will not be reused) to detach the original rear panel (#25 – Fig 1) and maneuver it out of the way. These are accessed behind the OEM console sides.

NOTE: Vehicles with electric windows will have switches mounted in this rear panel with a wiring harness (#26 – Figure 1). Leave these switches in the rear panel, they will be reused. There are (3) support clamps which attach the wiring harness to the bottom of the original insert (#27 – Fig 1) that will have to be popped out with a flat head screwdriver. (These may break when removed but they will not be reused). It is not necessary but it will make the installation easier if the switch harness is unplugged. The release clip for the plug is difficult to find, it is located on the bottom of the plug toward the front.

3. Maneuver the original insert (#27 – Fig 1) out of the original console (#24 – Fig 1) by popping it down and out of the tabs on the inside top front of the original console.

FIGURE 1

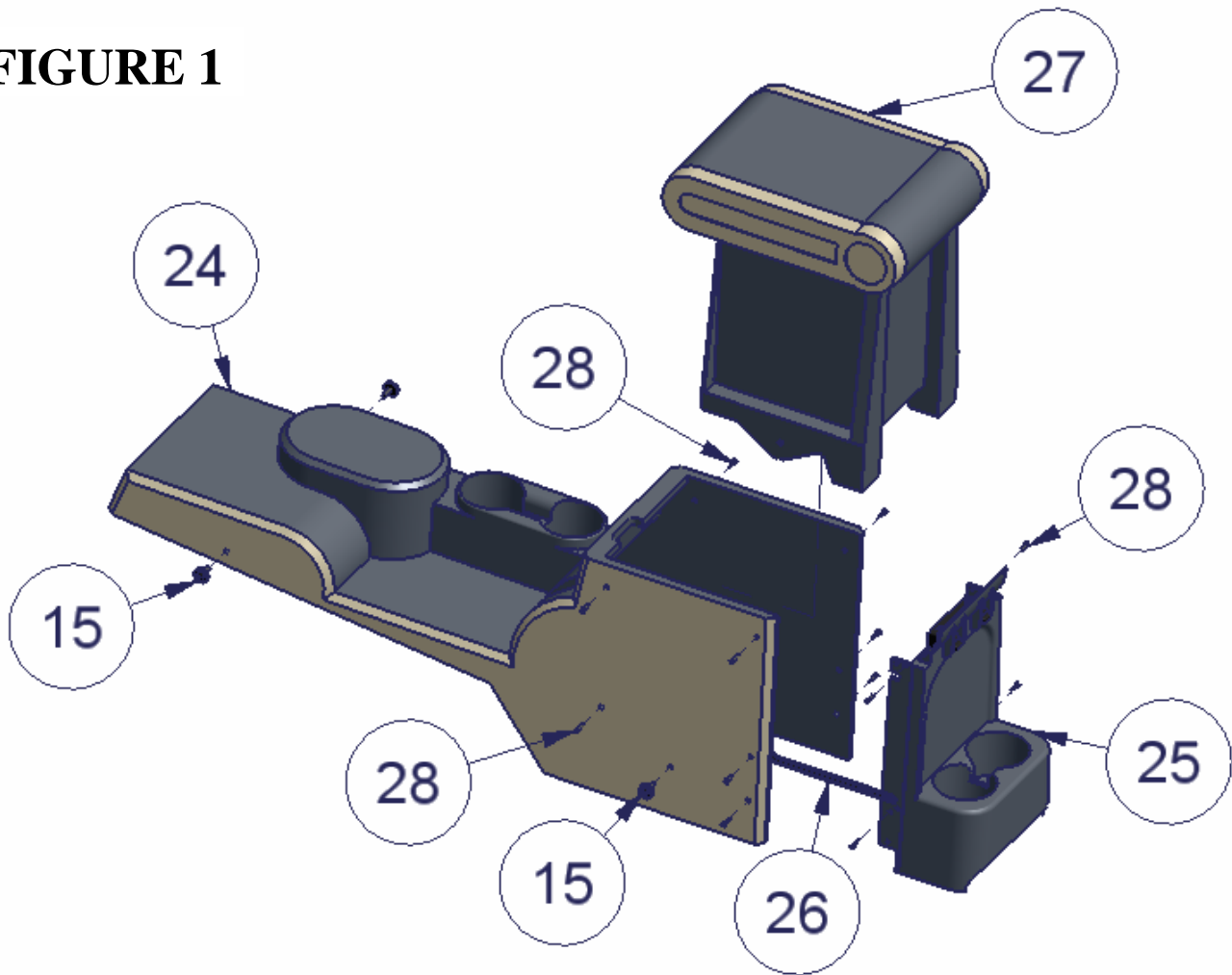
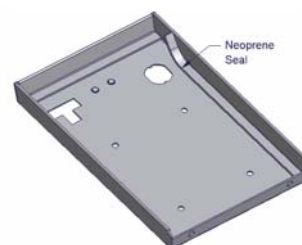

FIGURE 2

4. Install the rubber seal around the edge of the lid. (Fig 2)
5. Check the lock and latch operation.



OPTIONAL ADDITIONAL SECURITY STEP

- Place the Tuffy insert in the finished mounting position by lining up all the mounting holes and mark at least one spot on the vehicle floor under the 3/8" holes in the bottom of the Tuffy insert for drilling. (Fig 3)

WARNING! Make sure that there is nothing under/on the vehicle that will be damaged by the drill bit when drilling.

- Remove the Tuffy insert and drill a 1/4" pilot hole in each marked spot then drill them out to 3/8" holes. Use touch up paint or silicone sealant in any drilled holes to prevent rusting.
- Attach the original rear panel (#25 – Fig 3) to the Tuffy insert using the (4) supplied 6-32 x 3/4" Button socket cap screws. Make sure the bottom holes which are not used yet on the original rear panel are aligned with the nuts on the Tuffy insert when tightening this hardware. (#29 – Fig 3) If the switch harness is present on the original rear panel it will have to be maneuvered out of the way toward the passenger side then plugged back in.
- Attach the Tuffy insert to the original console (#24 – Fig 3) using the (10) supplied 6-32 x 3/4" Button socket cap screws #29 and (10) #6 Black Washers #30. It is easiest for alignment to insert all the screws a few turns starting with the rear bottom left and right screws then coming back and tightening them all. (#29 & #30– Fig 3). In rare cases a hole in the original plastic console will have to be obounded with a 3/16" drill bit if it does not line up with the hole on the Tuffy insert.
- Fasten the entire console assembly down using the (4) original OEM mounting torx screws (#15 Fig 1 & 3)
- If the optional additional security steps were done fasten down the Tuffy insert using the (2) 5/16-18 x 4 1/2" Hex cap screws, (2) Hex nylon insert nuts, & (4) 5/16" USS washers through the holes previously drilled. Do not over tighten. (#17, #18, #19 – Fig 3)

